

m o d e l **LX 25**

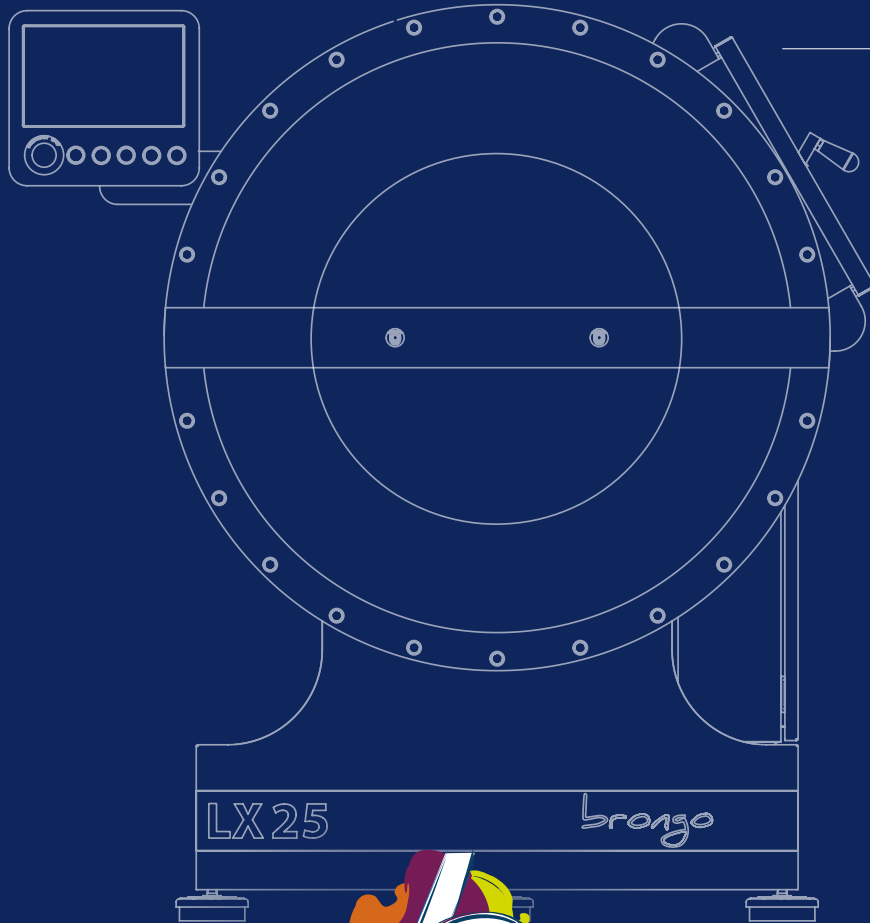

brongo

model

LX 25

made in Italy



Excellent mechanical abrasion provided by the shape and diameter of the drum.

Flexibility of a full optional machine, also having the B-Cloud nebulization built in as standard.

Full glass front which allows you to see the entire bath and understand the evolution of the process.

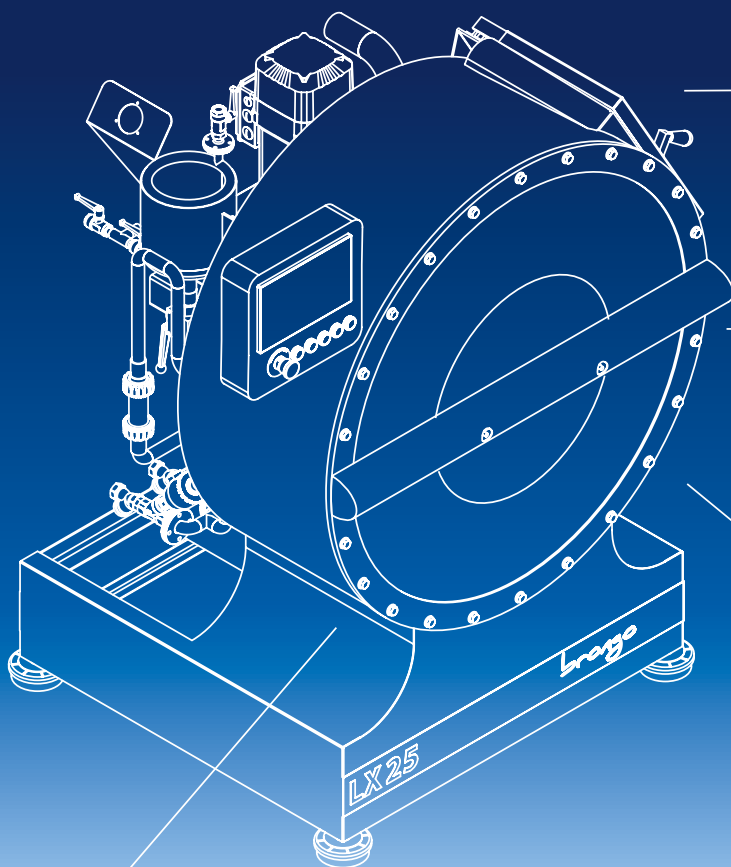

Very low and unbeatable liquor ratio thanks to the minimum distance between shell and drum, which allows you to wash few garments perfectly dipped in water, creating similar conditions to bulk

GARMENT

SAMPLING

Small-scale machine with open pocket drum and low spinning speed of extraction for sampling, particularly efficient for repeating treatments in production, for both washing and dyeing.

- Loading from the top.
- Robust and easy machine for industrial use, completely in Stainless Steel.
- Water inlet controlled by electronic liter-counter.
- One manual valve for products introduction into the machine.
- Direct and indirect steam with a coil under the shell.
- Video Terminal for automatic cycle control.



TECHNICAL FEATURES

Drum Diameter	940 mm
Drum Depth	380 mm
Drum Volume	1050 dm ³
Installed Power	1,1 kW
Power Supply	230/50 Volt/Hz
Max. Speed	10 0 rpm
Water Inlet	3/4" Inches
Steam Inlet	1/2" Inches

DIMENSIONS

Width	1400 mm
Depth	1300 mm
Height	1500 mm
Weight	500 Kg



www.brongo.com



BRONGO s.r.l. Via del Fornaccio 14, 50012 Bagno a Ripoli (FI) Italy
+39 055 696061 - brongo@brongo.com